

## Second Generation MLTL 40" Enclosure for JX92S Driver

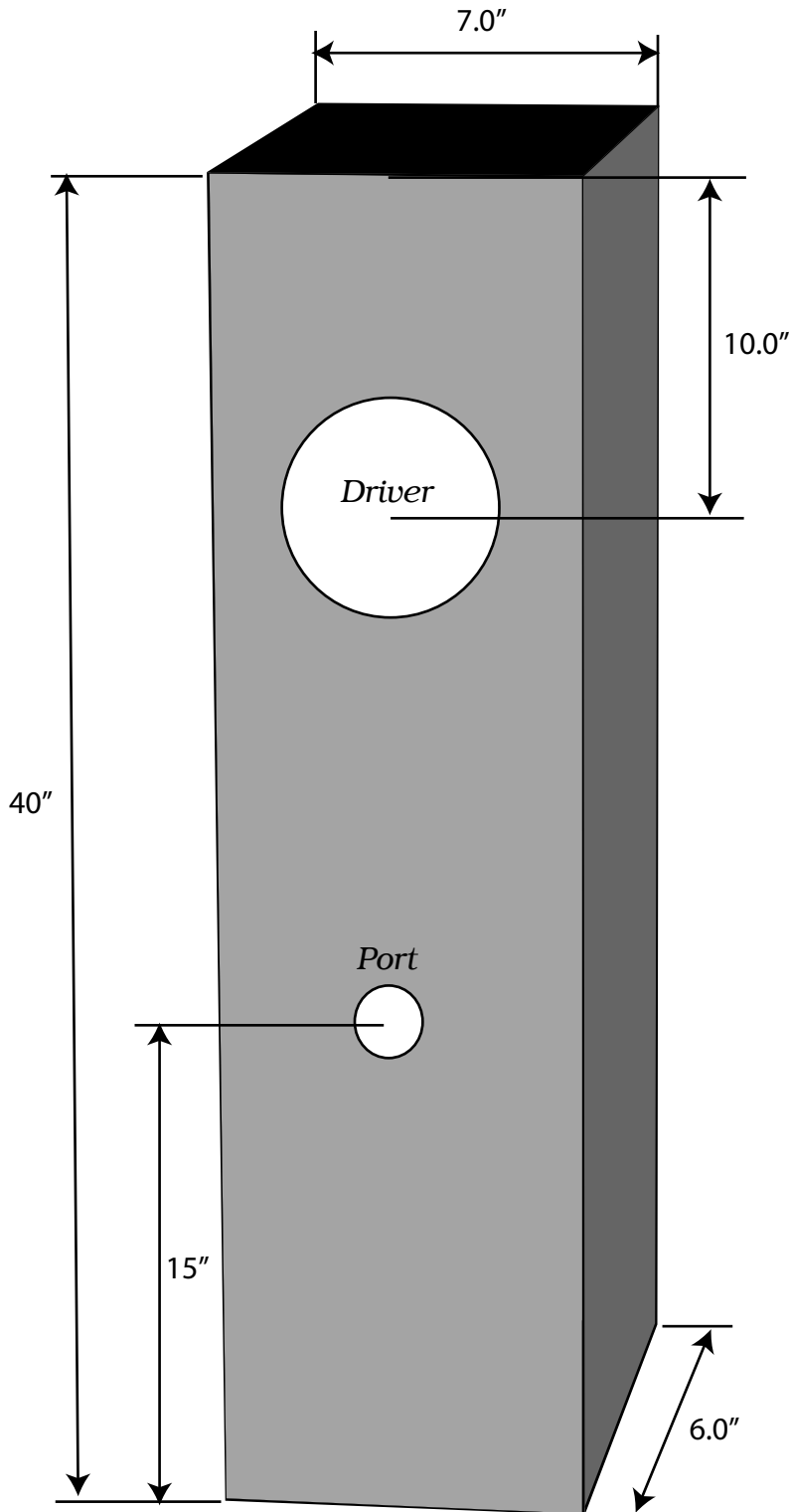

### **Notes:**

#### **All dimensions Internal**

- Recommended construction material is 3/4" MDF or equivalent.
- No special bracing is required but may be added at your discretion.
- Stuff from top down 15" with 0.20 Lbs. Lbs.. of Acousta-Stuf Parts Express: Sku 260-317 or equivalent
- Fluff stuffing up to the volume required and use 3M™ Super 77™ Multipurpose Adhesive to attach to the top and sides of cabinet.
- Additionally it is recommended that you use 3/4" Sonic Barrier directly behind the driver approximately 10" in height. Parts Express: Sku 260-530 or equivalent.
- Port: 2.0625 Inner Dia. X 5" Long Parts Express Sku 260-322
- Parts Express Sealing Caulk Sku 269-300 recommended.
- MDF and Furniture Grade Cabinets available from:

<http://www.Jordan-USA.com>

# Cutout Details for: JX92S Driver & Port

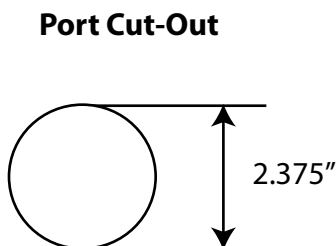
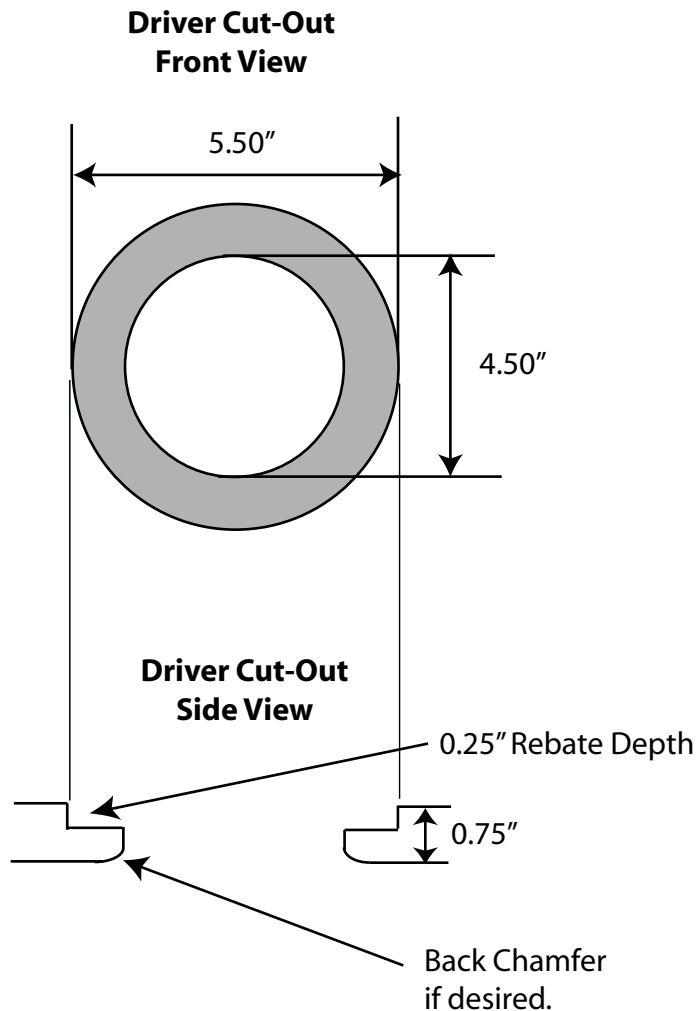

## Notes:

- Recommended construction material is 3/4" MDF or equivalent.
- No special bracing is required but may be added at your discretion.
- Rebate driver to a depth that provides flush mounting and use chamfer on back of driver mounting hole for smooth air flow.
- The driver requires a 4.5 in through hole that is then rebated to a depth of 0.25 inches (adjust based on gasketing material) and an internal diameter of 5.0"
- Parts Express Sealing Caulk Sku 269-300 recommended.
- The port requires a 2.375" (2 3/8") hole to accommodate the recommended Parts Express Sku 260-322 port. Others may be substituted.
- Recommended baffle step circuit is 0.75 mH with 3.0 Ohms in parallel. This should be adjusted based on taste and room position.
- Always adjust stuffing to suit your taste!
- Typical range of inductors is 0.5 to 1.5 mH and 3 or 4 Ohms in parallel.

**MDF and Furniture Grade Cabinets available from:**

<http://www.Jordan-USA.com>

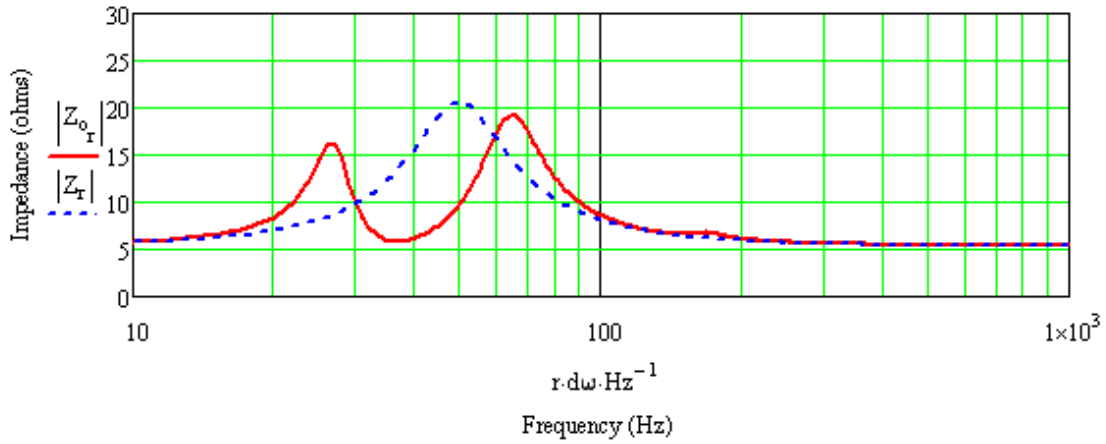
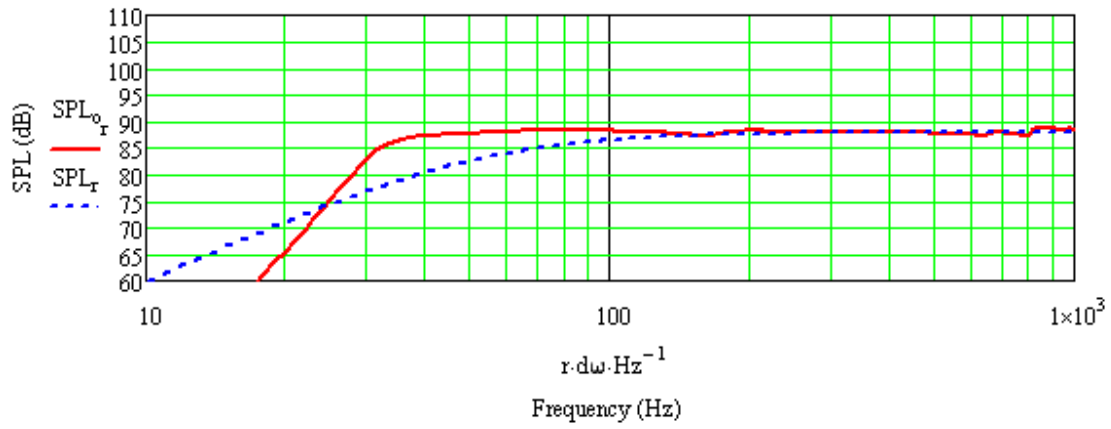

Woofer Displacement

