



JORDAN JXR6HD.

This exciting new driver is the long-awaited successor to the Jordan JX53. It is the world's widest bandwidth 2 inch driver and represents the leading edge of moving cone driver design. It is the culmination of Ted Jordan's 50 years of experience in the field.

The JXR6 HD features the unique Jordan Controflex metal cone in an improved suspension which allows this unit to effortlessly cover the range 100Hz to 30kHz. The resonant frequency of this unit is 95Hz which allows a single unit, in a 1 liter, totally enclosed box, to form the basis for a superb, satellite/sub-bass system together with JX125NG or JX150NG.

The JXR6 HD cone sits in a highly advanced chassis. This is constructed of a specialised compound of plastic and polycarbonate, unique to us. It is extremely rigid and resonance-absorbing, making it a very stable, small driver platform. The leadout wires are incorporated into the chassis design, making assembly into cabinets very easy. Manufactured in a specialised facility, the whole unit has a precision camera feel to it.

The JXR6 HD driver may also be used in multiple arrays, facilitated by the rectangular chassis. A Vertical, Linear Array System provides the most dramatic re-creation of live stage realism ever achieved. See SYSTEMS for details of how to use this unique drive unit.

Note, when measuring this driver, please use analogue direct measuring methods, rather than computer derived measures which will involve too many errors.

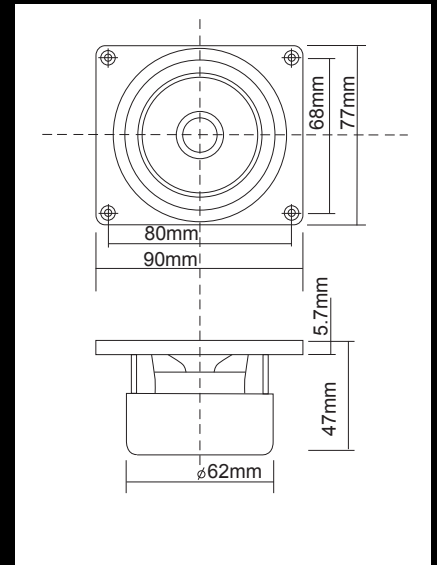

Measures

Thiele/Small Parameters JXR6HD		
Qts =	0.52	Total Q
Qes =	0.87	Electrical Q
Qms =	1.29	Mechanical Q
Fs =	95 Hertz	+/-5% Free Air Resonance
Res =	4.4 Ohms	DC resistance
Ls =	92 u H	series inductance
Lp =	48 u H	lossy series inductance
Rp =	1.0 Ohms	loss across Lp
Dia =	57 m.m.	effective
(%shift)	29.3 %	resonance with box
Vas =	2.3 liters	air volume equivalent
mms =	1.1 grams	effective mass
cms =	2.6 m m/N	compliance
bl =	1.8 T*m	motor strength
n0 =	221 m %	max efficiency
SplSens =	85 dBSPL	max @1W absorbed
(Box Volume)	2	liters
Xmax	+/- 1.4	mm. p-p

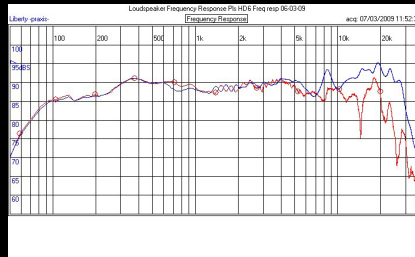

Frequency

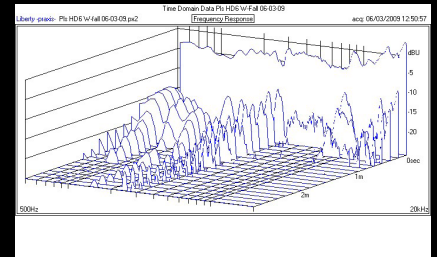

Waterfall